

## Brushed DC Motor Fundamentals

Author: Reston Condit  
Microchip Technology Inc.

### INTRODUCTION

Brushed DC motors are widely used in applications ranging from toys to push-button adjustable car seats. Brushed DC (BDC) motors are inexpensive, easy to drive, and are readily available in all sizes and shapes. This application note will discuss how a BDC motor works, how to drive a BDC motor, and how a drive circuit can be interfaced to a PIC<sup>®</sup> microcontroller.

### PRINCIPLES OF OPERATION

The construction of a simple BDC motor is shown in Figure 1. All BDC motors are made of the same basic components: a stator, rotor, brushes and a commutator. The following paragraphs will explain each component in greater detail.

### Stator

The stator generates a stationary magnetic field that surrounds the rotor. This field is generated by either permanent magnets or electromagnetic windings. The different types of BDC motors are distinguished by the construction of the stator or the way the electromagnetic windings are connected to the power source. (See **Types of Stepping Motors** for the different BDC motor types).

### Rotor

The rotor, also called the armature, is made up of one or more windings. When these windings are energized they produce a magnetic field. The magnetic poles of this rotor field will be attracted to the opposite poles generated by the stator, causing the rotor to turn. As the motor turns, the windings are constantly being energized in a different sequence so that the magnetic poles generated by the rotor do not overrun the poles generated in the stator. This switching of the field in the rotor windings is called commutation.

**FIGURE 1: SIMPLE TWO-POLE BRUSHED DC MOTOR**

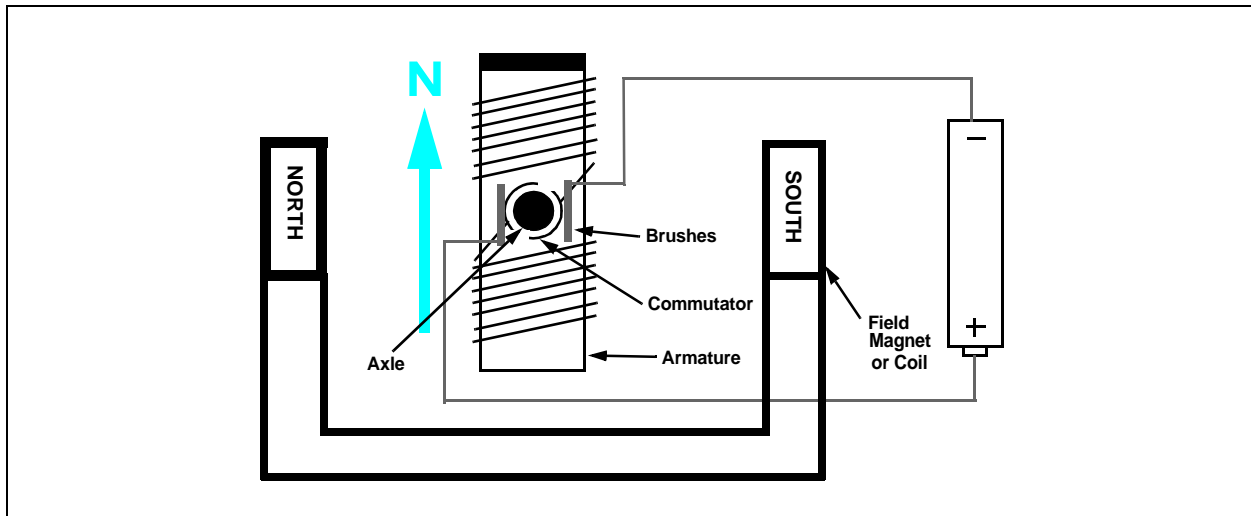

## Brushes and Commutator

Unlike other electric motor types (i.e., brushless DC, AC induction), BDC motors do not require a controller to switch current in the motor windings. Instead, the commutation of the windings of a BDC motor is done mechanically. A segmented copper sleeve, called a commutator, resides on the axle of a BDC motor. As the motor turns, carbon brushes slide over the commutator, coming in contact with different segments of the commutator. The segments are attached to different rotor windings, therefore, a dynamic magnetic field is generated inside the motor when a voltage is applied across the brushes of the motor. It is important to note that the brushes and commutator are the parts of a BDC motor that are most prone to wear because they are sliding past each other.

## TYPES OF STEPPING MOTORS

As mentioned earlier, the way the stationary magnetic field is produced in the stator differentiates the various types of BDC motors. This section will discuss the different types of BDC motors and the advantages/disadvantages of each.

### Permanent Magnet

Permanent Magnet Brushed DC (PMDC) motors are the most common BDC motors found in the world. These motors use permanent magnets to produce the stator field. PMDC motors are generally used in applications involving fractional horsepower because it is more cost effective to use permanent magnets than wound stators. The drawback of PMDC motors is that the magnets lose their magnetic properties over time. Some PMDC motors have windings built into them to prevent this from happening. The performance curve (voltage vs. speed), is very linear for PMDC motors. Current draw also varies linearly with torque. These motors respond to changes in voltage very quickly because the stator field is always constant.

**FIGURE 2: PERMANENT MAGNET DC MOTORS**

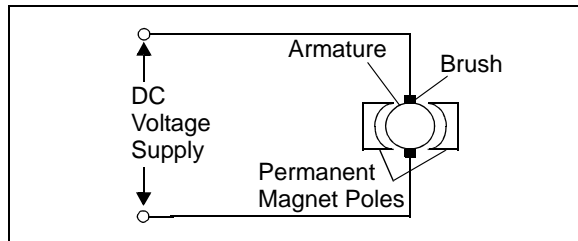

### Shunt-Wound

Shunt-wound Brushed DC (SHWDC) motors have the field coil in parallel (shunt) with the armature. The current in the field coil and the armature are independent of one another. As a result, these motors have excellent speed control. SHWDC motors are typically used in applications that require five or more horsepower. Loss of magnetism is not an issue in SHWDC motors so they are generally more robust than PMDC motors.

**FIGURE 3: SHUNT-WOUND DC MOTORS**

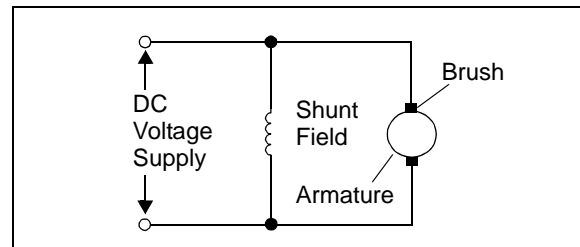

### Series-Wound

Series-wound Brushed DC (SWDC) motors have the field coil in series with the armature. These motors are ideally suited for high-torque applications because the current in both the stator and armature increases under load. A drawback to SWDC motors is that they do not have precise speed control like PMDC and SHWDC motors have.

**FIGURE 4: SERIES-WOUND DC MOTORS**

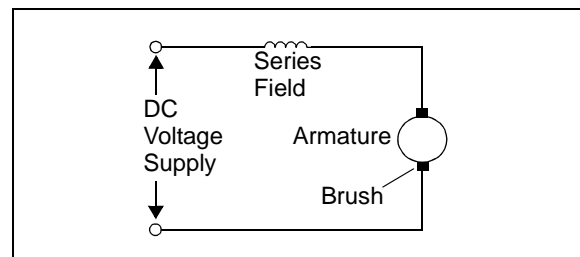

## Compound-Wound

Compound Wound (CWDC) motors are a combination of shunt-wound and series-wound motors. As shown in Figure 5, CWDC motors employ both a series and a shunt field. The performance of a CWDC motor is a combination of SWDC and SHWDC motors. CWDC motors have higher torque than a SHWDC motor while offering better speed control than a SWDC motor.

**FIGURE 5: COMPOUND-WOUND DC MOTORS**

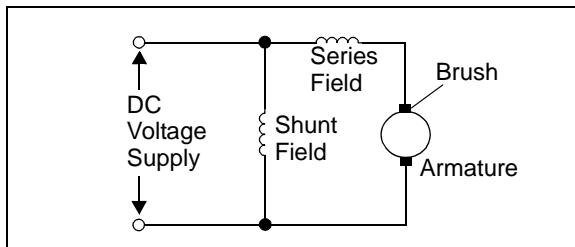

## BASIC DRIVE CIRCUITS

Drive circuits are used in applications where a controller of some kind is being used and speed control is required. The purpose of a drive circuit is to give the controller a way to vary the current in the windings of the BDC motor. The drive circuits discussed in this section allow the controller to pulse-width modulate the voltage supplied to a BDC motor. In terms of power consumption, this method of speed control is a far more efficient way to vary the speed of a BDC motor compared to traditional analog control methods. Traditional analog control required the addition of an inefficient variable resistance in series with the motor.

BDC motors are driven in a variety of ways. In some cases the motor only needs to spin in one direction. Figure 6 and Figure 7 show circuits for driving a BDC motor in one direction. The first is a low-side drive and the second is a high-side drive. The advantage to using the low-side drive is that a FET driver is not typically needed. A FET driver is used to:

1. bring the TTL signal driving a MOSFET to the potential level of the supply voltage,
2. provide enough current to drive the MOSFET<sup>(1)</sup>,
3. and provide level shifting in half-bridge applications.

**Note:** The second point typically does not apply to most PIC<sup>®</sup> microcontroller applications because PIC MCU I/O pins can source 20 mA.

Note that in each circuit there is a diode across the motor. This diode is there to prevent Back Electromagnetic Flux (BEMF) voltage from harming the MOSFET. BEMF is generated when the motor is spinning. When the MOSFET is turned off, the winding in the motor is still charged at this point and will produce reverse current flow. D1 must be rated appropriately so that it will dissipate this current.

**FIGURE 6: LOW-SIDE BDC MOTOR DRIVE CIRCUIT**

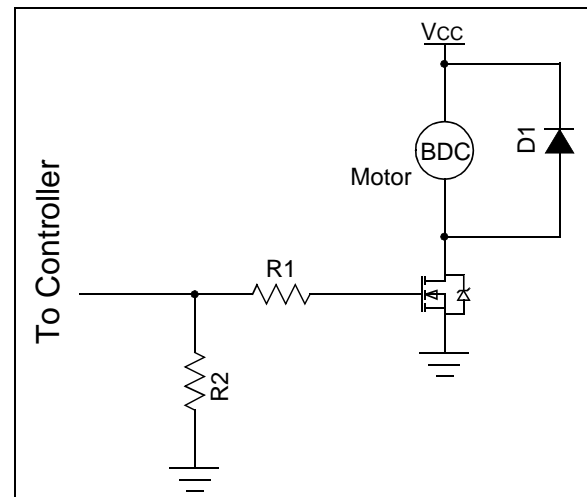

**FIGURE 7: HIGH-SIDE BDC MOTOR DRIVE CIRCUIT**

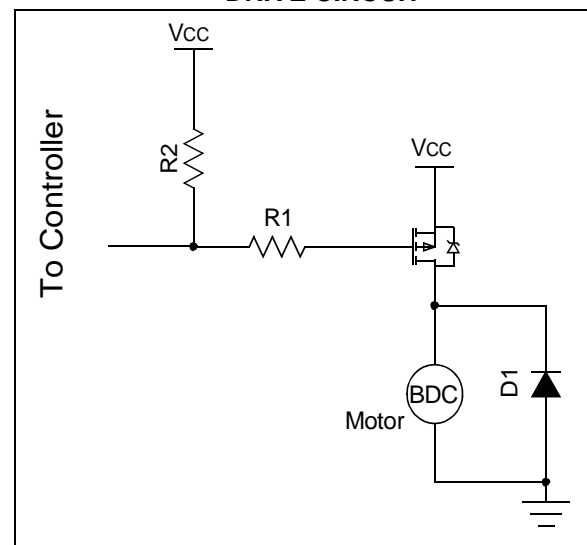

Resistors R1 and R2 in Figure 6 and Figure 7 are important to the operation of each circuit. R1 protects the microcontroller from current spikes while R2 ensures that Q1 is turned off when the input pin is tri-stated.

# AN905

Bidirectional control of a BDC motor requires a circuit called an H-bridge. The H-bridge, named for its schematic appearance, is able to move current in either direction through the motor winding. To understand this, the H-bridge must be broken into its two sides, or half-bridges. Referring to Figure 8, Q1 and Q2 make up one half-bridge while Q3 and Q4 make up the other half-bridge. Each of these half-bridges is able to switch one side of the BDC motor to the potential of the supply voltage or ground. When Q1 is turned on and Q2 is off, for instance, the left side of the motor will be at the potential of the supply voltage. Turning on Q4 and leaving Q3 off will ground the opposite side of the motor. The arrow labeled  $I_{FWD}$  shows the resulting current flow for this configuration.

Note the diodes across each of the MOSFETs (D1-D4). These diodes protect the MOSFETs from current spikes generated by BEMF when the MOSFETs are switched off. These diodes are only needed if the internal MOSFET diodes are not sufficient for dissipating the BEMF current.

The capacitors (C1-C4) are optional. The value of these capacitors is generally in the 10 pF range. The purpose of these capacitors is to reduce the RF radiation that is produced by the arching of the commutators.

**FIGURE 8: BIDIRECTION BDC MOTOR DRIVE (H-BRIDGE) CIRCUIT**

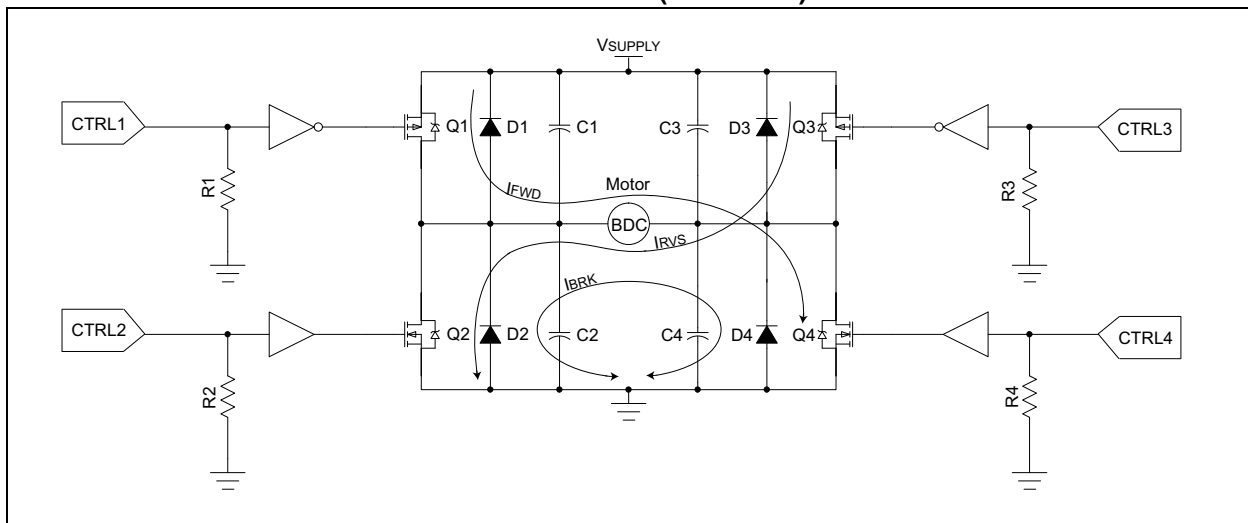

The different drive modes for an H-bridge circuit are shown in Table 1. In Forward mode and Reverse mode one side of the bridge is held at ground potential and the other side at  $V_{SUPPLY}$ . In Figure 8 the  $I_{FWD}$  and  $I_{RVS}$  arrows illustrate the current paths during the Forward and Reverse modes of operation. In Coast mode, the ends of the motor winding are left floating and the motor coasts to a stop. Brake mode is used to rapidly stop the BDC motor. In Brake mode, the ends of the motor are grounded. The motor behaves as a generator when it is rotating. Shorting the leads of the motor acts as a load of infinite magnitude bringing the motor to a rapid halt. The  $I_{BRK}$  arrow illustrates this.

There is one very important consideration that must be taken into account when designing an H-bridge circuit. All MOSFETs must be biased to off when the inputs to the circuit are unpredictable (like when the microcontroller is starting up). This will ensure that the MOSFETs on each half-bridge of the H-bridge will never be turned on at the same time. *Turning MOSFETs on that are located on the same half-bridge will cause a short across the power supply, ultimately damaging the MOSFETs and rendering the circuit inoperable.* Pull-down resistors at each of the MOSFET driver inputs will accomplish this functionality (for the configuration shown in Figure 8).

**TABLE 1: H-BRIDGE MODES OF OPERATION**

	Q1 (CTRL1)	Q2 (CTRL2)	Q3 (CTRL3)	Q4 (CTRL4)
Forward	on	off	off	on
Reverse	off	on	on	off
Coast	off	off	off	off
Brake	off	on	off	on

## SPEED CONTROL

The speed of a BDC motor is proportional to the voltage applied to the motor. When using digital control, a pulse-width modulated (PWM) signal is used to generate an average voltage. The motor winding acts as a low pass filter so a PWM waveform of sufficient frequency will generate a stable current in the motor winding. The relation between average voltage, the supply voltage, and duty cycle is given by:

### EQUATION 1:

$$V_{AVERAGE} = D \times V_{SUPPLY}$$

Speed and duty cycle are proportional to one another. For example, if a BDC motor is rated to turn at 15000 RPM at 12V, the motor will (ideally) turn at 7500 RPM when a 50% duty cycle waveform is applied across the motor.

The frequency of the PWM waveform is an important consideration. Too low a frequency will result in a noisy motor at low speeds and sluggish response to changes in duty cycle. Too high a frequency lessens the efficiency of the system due to switching losses in the switching devices. A good rule of thumb is to modulate the input waveform at a frequency in the range of 4 kHz to 20 kHz. This range is high enough that audible motor noise is attenuated and the switching losses present in the MOSFETs (or BJTs) are negligible. Generally, it is a good idea to experiment with the PWM frequency for a given motor to find a satisfactory frequency.

So how can a PIC microcontroller be used to generate the PWM waveform required to control the speed of a BDC motor? One way would be to toggle an output pin by writing assembly or C code dedicated to driving that pin<sup>(1)</sup>. Another way is to select a PIC microcontroller with a hardware PWM module. The modules available from Microchip for this purpose are the CCP and ECCP modules. Many of the PIC microcontrollers have CCP and ECCP modules. Refer to the product selector guide to find the devices having these features.

**Note:** Microchip Application Note AN847 provides an assembly code routine for pulse-width modulating an I/O pin in firmware.

The CCP module (short for Capture Compare and PWM) is capable of outputting a 10-bit resolution PWM waveform on a single I/O pin. 10-bit resolution means that  $2^{10}$ , or 1024, possible duty cycle values ranging from 0% to 100% are achievable by the module. The advantage to using this module is that it automatically generates a PWM signal on an I/O pin which frees up processor time for doing other things. The CCP module only requires that the developer configure the parameters of the module. Configuring the module includes setting the frequency and duty cycle registers.

The ECCP module (short for Enhanced Capture Compare and PWM) provides the same functionality as the CCP module with the added capability of driving a full or half-bridge circuit. The ECCP module also has auto-shutdown capability and programmable dead band delay.

**Note:** Microchip Application Note AN893 gives a detailed explanation of configuring the ECCP module for driving a BDC motor. The application note also includes firmware and drive circuit examples.

## FEEDBACK MECHANISMS

Though the speed of a BDC motor is generally proportional to duty cycle, no motor is ideal. Heat, commutator wear and load all affect the speed of a motor. In systems where precise speed control is required, it is a good idea to include some sort of feedback mechanism in the system.

Speed feedback is implemented in one of two ways. The first involves the use of a speed sensor of some kind. The second uses the BEMF voltage generated by the motor.

### Sensored Feedback

There are a variety of sensors used for speed feedback. The most common are optical encoders and hall effect sensors. Optical encoders are made up of several components. A slotted wheel is mounted to the shaft at the non-driving end of the motor. An infrared LED provides a light source on one side of the wheel and a photo transistor detects light on the other side of the wheel (see Figure 9). Light passing through the slots in the wheel will turn the photo transistor on. As the shaft turns, the photo transistor turns on and off with the passing of the slots in the wheel. The frequency at which the transistor toggles is an indication of motor speed. In the case of positioning applications, an optical encoder will also provide feedback as to the position of the motor.

**FIGURE 9: OPTICAL ENCODER**

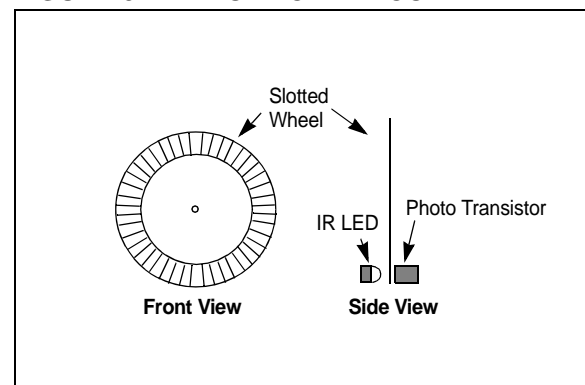

# AN905

Hall effect sensors are also used to provide speed feedback. Like optical encoders, Hall effect sensors require a rotary element attached to the motor and a stationary component. The rotary element is a wheel with one or more magnets positioned on its outer rim. A stationary sensor detects the magnet when it passes and generates a TTL pulse. Figure 10 shows the basic components of a Hall effect sensor.

**FIGURE 10: HALL EFFECT SENSOR**

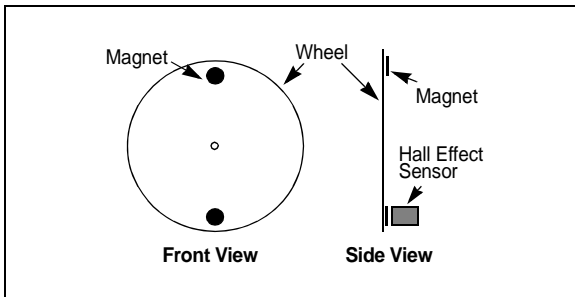

## Back Electro Magnetic Flux (BEMF)

Another form of velocity feedback for a BDC motor is BEMF voltage measurement. BEMF voltage and speed are proportional to one another. Figure 11 shows the locations where BEMF voltage is measured on a bidirectional drive circuit. A voltage divider is used to drop the BEMF voltage into the 0-5V range so that it can be read by an analog-to-digital converter. The BEMF voltage is measured between PWM pulses when one side of the motor is floating and the other is grounded. At this instance in time the motor is acting like a generator and produces a BEMF voltage proportional to speed.

**FIGURE 11: BACK EMF VOLTAGE MEASUREMENT**

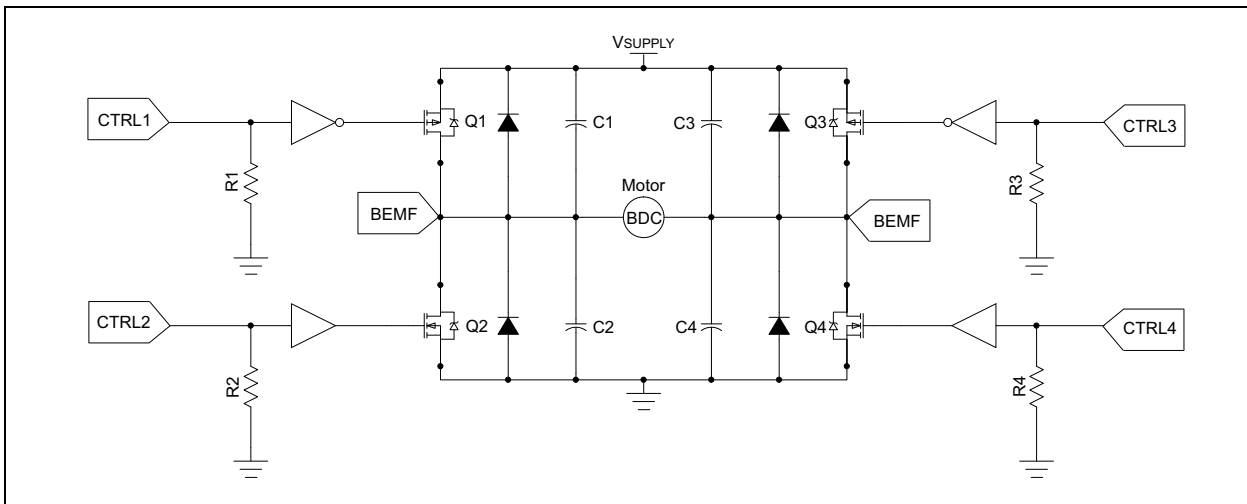

All BDC motors behave slightly differently because of differences in efficiency and materials. Experimentation is the best way to determine the BEMF voltage for a given motor speed. A piece of reflect tape on the shaft of the motor will allow a digital tachometer to measure the RPM of the motor. Measuring the BEMF voltage while reading the digital tachometer will give a correlation between motor speed and BEMF voltage.

**Note:** Microchip Application Note AN893 provides firmware and circuit examples for reading the BEMF voltage using a PIC16F684.

## CONCLUSION

Brushed DC motors are very simple to use and control, which makes them a short design-in item. PIC microcontrollers, especially those with CCP or ECCP modules, are ideally suited for driving BDC motors.

## REFERENCES

AN893, "*Low-Cost Bidirectional Brushed DC Motor Control Using the PIC16F684*".

AN847, "*RC Model Aircraft Motor Control*".

[www.howstuffworks.com](http://www.howstuffworks.com)

[www.engin.umich.edu/labs/csdl/me350/motors/dc/index.html](http://www.engin.umich.edu/labs/csdl/me350/motors/dc/index.html)

# AN905

---

NOTES:



---

**Note the following details of the code protection feature on Microchip devices:**

- Microchip products meet the specification contained in their particular Microchip Data Sheet.
- Microchip believes that its family of products is one of the most secure families of its kind on the market today, when used in the intended manner and under normal conditions.
- There are dishonest and possibly illegal methods used to breach the code protection feature. All of these methods, to our knowledge, require using the Microchip products in a manner outside the operating specifications contained in Microchip's Data Sheets. Most likely, the person doing so is engaged in theft of intellectual property.
- Microchip is willing to work with the customer who is concerned about the integrity of their code.
- Neither Microchip nor any other semiconductor manufacturer can guarantee the security of their code. Code protection does not mean that we are guaranteeing the product as "unbreakable."

Code protection is constantly evolving. We at Microchip are committed to continuously improving the code protection features of our products. Attempts to break Microchip's code protection feature may be a violation of the Digital Millennium Copyright Act. If such acts allow unauthorized access to your software or other copyrighted work, you may have a right to sue for relief under that Act.

---

Information contained in this publication regarding device applications and the like is provided only for your convenience and may be superseded by updates. It is your responsibility to ensure that your application meets with your specifications. MICROCHIP MAKES NO REPRESENTATIONS OR WARRANTIES OF ANY KIND WHETHER EXPRESS OR IMPLIED, WRITTEN OR ORAL, STATUTORY OR OTHERWISE, RELATED TO THE INFORMATION, INCLUDING BUT NOT LIMITED TO ITS CONDITION, QUALITY, PERFORMANCE, MERCHANTABILITY OR FITNESS FOR PURPOSE. Microchip disclaims all liability arising from this information and its use. Use of Microchip devices in life support and/or safety applications is entirely at the buyer's risk, and the buyer agrees to defend, indemnify and hold harmless Microchip from any and all damages, claims, suits, or expenses resulting from such use. No licenses are conveyed, implicitly or otherwise, under any Microchip intellectual property rights.

**Trademarks**

The Microchip name and logo, the Microchip logo, dsPIC, KEELOQ, KEELOQ logo, MPLAB, PIC, PICmicro, PICSTART, PIC<sup>32</sup> logo, rPIC and UNI/O are registered trademarks of Microchip Technology Incorporated in the U.S.A. and other countries.

FilterLab, Hampshire, HI-TECH C, Linear Active Thermistor, MXDEV, MXLAB, SEEVAL and The Embedded Control Solutions Company are registered trademarks of Microchip Technology Incorporated in the U.S.A.

Analog-for-the-Digital Age, Application Maestro, CodeGuard, dsPICDEM, dsPICDEM.net, dsPICworks, dsSPEAK, ECAN, ECONOMONITOR, FanSense, HI-TIDE, In-Circuit Serial Programming, ICSP, Mindi, MiWi, MPASM, MPLAB Certified logo, MPLIB, MPLINK, mTouch, Omniscient Code Generation, PICC, PICC-18, PICDEM, PICDEM.net, PICKit, PICtail, REAL ICE, rLAB, Select Mode, Total Endurance, TSHARC, UniWinDriver, WiperLock and ZENA are trademarks of Microchip Technology Incorporated in the U.S.A. and other countries.

SQTP is a service mark of Microchip Technology Incorporated in the U.S.A.

All other trademarks mentioned herein are property of their respective companies.

© 2010, Microchip Technology Incorporated, Printed in the U.S.A., All Rights Reserved.

 Printed on recycled paper.

ISBN: 978-1-60932-665-4

*Microchip received ISO/TS-16949:2002 certification for its worldwide headquarters, design and wafer fabrication facilities in Chandler and Tempe, Arizona; Gresham, Oregon and design centers in California and India. The Company's quality system processes and procedures are for its PIC<sup>®</sup> MCUs and dsPIC<sup>®</sup> DSCs, KEELOQ<sup>®</sup> code hopping devices, Serial EEPROMs, microperipherals, nonvolatile memory and analog products. In addition, Microchip's quality system for the design and manufacture of development systems is ISO 9001:2000 certified.*

**QUALITY MANAGEMENT SYSTEM  
CERTIFIED BY DNV  
== ISO/TS 16949:2002 ==**



# MICROCHIP

## Worldwide Sales and Service

### AMERICAS

**Corporate Office**  
2355 West Chandler Blvd.  
Chandler, AZ 85224-6199  
Tel: 480-792-7200  
Fax: 480-792-7277  
Technical Support:  
<http://support.microchip.com>  
Web Address:  
[www.microchip.com](http://www.microchip.com)

**Atlanta**  
Duluth, GA  
Tel: 678-957-9614  
Fax: 678-957-1455

**Boston**  
Westborough, MA  
Tel: 774-760-0087  
Fax: 774-760-0088

**Chicago**  
Itasca, IL  
Tel: 630-285-0071  
Fax: 630-285-0075

**Cleveland**  
Independence, OH  
Tel: 216-447-0464  
Fax: 216-447-0643

**Dallas**  
Addison, TX  
Tel: 972-818-7423  
Fax: 972-818-2924

**Detroit**  
Farmington Hills, MI  
Tel: 248-538-2250  
Fax: 248-538-2260

**Kokomo**  
Kokomo, IN  
Tel: 765-864-8360  
Fax: 765-864-8387

**Los Angeles**  
Mission Viejo, CA  
Tel: 949-462-9523  
Fax: 949-462-9608

**Santa Clara**  
Santa Clara, CA  
Tel: 408-961-6444  
Fax: 408-961-6445

**Toronto**  
Mississauga, Ontario,  
Canada  
Tel: 905-673-0699  
Fax: 905-673-6509

### ASIA/PACIFIC

**Asia Pacific Office**  
Suites 3707-14, 37th Floor  
Tower 6, The Gateway  
Harbour City, Kowloon  
Hong Kong  
Tel: 852-2401-1200  
Fax: 852-2401-3431

**Australia - Sydney**  
Tel: 61-2-9868-6733  
Fax: 61-2-9868-6755

**China - Beijing**  
Tel: 86-10-8528-2100  
Fax: 86-10-8528-2104

**China - Chengdu**  
Tel: 86-28-8665-5511  
Fax: 86-28-8665-7889

**China - Chongqing**  
Tel: 86-23-8980-9588  
Fax: 86-23-8980-9500

**China - Hong Kong SAR**  
Tel: 852-2401-1200  
Fax: 852-2401-3431

**China - Nanjing**  
Tel: 86-25-8473-2460  
Fax: 86-25-8473-2470

**China - Qingdao**  
Tel: 86-532-8502-7355  
Fax: 86-532-8502-7205

**China - Shanghai**  
Tel: 86-21-5407-5533  
Fax: 86-21-5407-5066

**China - Shenyang**  
Tel: 86-24-2334-2829  
Fax: 86-24-2334-2393

**China - Shenzhen**  
Tel: 86-755-8203-2660  
Fax: 86-755-8203-1760

**China - Wuhan**  
Tel: 86-27-5980-5300  
Fax: 86-27-5980-5118

**China - Xian**  
Tel: 86-29-8833-7252  
Fax: 86-29-8833-7256

**China - Xiamen**  
Tel: 86-592-2388138  
Fax: 86-592-2388130

**China - Zhuhai**  
Tel: 86-756-3210040  
Fax: 86-756-3210049

### ASIA/PACIFIC

**India - Bangalore**  
Tel: 91-80-3090-4444  
Fax: 91-80-3090-4123

**India - New Delhi**  
Tel: 91-11-4160-8631  
Fax: 91-11-4160-8632

**India - Pune**  
Tel: 91-20-2566-1512  
Fax: 91-20-2566-1513

**Japan - Yokohama**  
Tel: 81-45-471- 6166  
Fax: 81-45-471-6122

**Korea - Daegu**  
Tel: 82-53-744-4301  
Fax: 82-53-744-4302

**Korea - Seoul**  
Tel: 82-2-554-7200  
Fax: 82-2-558-5932 or  
82-2-558-5934

**Malaysia - Kuala Lumpur**  
Tel: 60-3-6201-9857  
Fax: 60-3-6201-9859

**Malaysia - Penang**  
Tel: 60-4-227-8870  
Fax: 60-4-227-4068

**Philippines - Manila**  
Tel: 63-2-634-9065  
Fax: 63-2-634-9069

**Singapore**  
Tel: 65-6334-8870  
Fax: 65-6334-8850

**Taiwan - Hsin Chu**  
Tel: 886-3-6578-300  
Fax: 886-3-6578-370

**Taiwan - Kaohsiung**  
Tel: 886-7-213-7830  
Fax: 886-7-330-9305

**Taiwan - Taipei**  
Tel: 886-2-2500-6610  
Fax: 886-2-2508-0102

**Thailand - Bangkok**  
Tel: 66-2-694-1351  
Fax: 66-2-694-1350

### EUROPE

**Austria - Wels**  
Tel: 43-7242-2244-39  
Fax: 43-7242-2244-393

**Denmark - Copenhagen**  
Tel: 45-4450-2828  
Fax: 45-4485-2829

**France - Paris**  
Tel: 33-1-69-53-63-20  
Fax: 33-1-69-30-90-79

**Germany - Munich**  
Tel: 49-89-627-144-0  
Fax: 49-89-627-144-44

**Italy - Milan**  
Tel: 39-0331-742611  
Fax: 39-0331-466781

**Netherlands - Drunen**  
Tel: 31-416-690399  
Fax: 31-416-690340

**Spain - Madrid**  
Tel: 34-91-708-08-90  
Fax: 34-91-708-08-91

**UK - Wokingham**  
Tel: 44-118-921-5869  
Fax: 44-118-921-5820

08/04/10